

Ananalysis And Design Of Llc Resonant Converter

Lokesha M H¹, Dr.S G Srivani²

¹PG student, Dept of Electrical and Electrical Engineering, RV College of Engineering, Bangalore, Karnataka, 560059, India

²Associate Professor, Dept of Electrical and Electrical Engineering, RV College of Engineering, Bangalore, Karnataka, 560059, India

Abstract

High efficiency, power density and Reliability are the basic requirements of any converter. Inductor Inductor Capacitor (LLC) resonant converter is most suitable resonant converter for front end DC-DC applications. Integrated magnetic, ZVS and high frequency operation, make the converter more compact and efficient. In this paper brief analysis of the LLC resonant converter is discussed. The prototype of the same is developed and it is tested.

Keywords: LLC, ZVS, high frequency, FHA.

1. Introduction

In today's highly competitive industrial environment designer always strive for highly efficient, reliable, and highly compact design. DC-DC converter technology has evolved from earlier lossy linear power converters to today's advanced resonant converters. Problems such as high switching losses and inability to operate at high frequencies, associated with the PWM converters can easily be overcome by using resonant converters. For front end DC-DC application LLC is the best suitable topology as compare with the other resonant converter [1] [2] [3]. Problem associated, with the Series resonant converter such as inability to regulate the output voltage at no-load condition and that with the Parallel resonant converter such as presence of high circulating energy can easily be overcome by LLC resonant converter.

Several aspects of LLC resonant converter are discussed in many papers. High frequency operation results in reduced size of magnetic components. But in resonant converters the advantage gained with the high frequency operation is lost as it requires additional reactive elements [4]. With the integrated magnetics several magnetic components can be constructed in one magnetic core[4][5]. Major advantage of LLC resonant converter is that the leakage inductance of the transformer can be used as resonant inductance and

together with the resonant capacitor it participate in the energy transfer mechanism [5]. But the integrated magnetic structure results in the inclusion of equal amount of leakage inductor on secondary side too. So that LLC with the center tapped secondary rectifier will experiences a large voltage oscillation, due to the presence of secondary leakage inductance [5]. In LLC resonant converter it is possible to regulate output voltage even at no-load condition [6]. Another significant advantage of LLC is ZVS turn on of primary switches; this reduces the switching losses dramatically.

In this paper full bridge LLC resonant converter is analyzed thoroughly, the prototype of the same is designed using first harmonic approximation method.

2. FULL BRIDGE LLC RESONANT CONVERTER

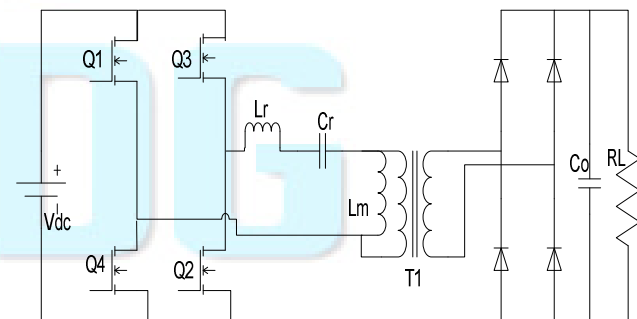

Fig.1. LLC Resonant Converter

The square waveform generated by the input full bridge is applied to the resonant tank formed by L_m , C_r , L_r and the load is connected in parallel with L_m . The DC characteristics of LLC resonant converter is shown in the figure. The DC characteristics of the LLC can be divided

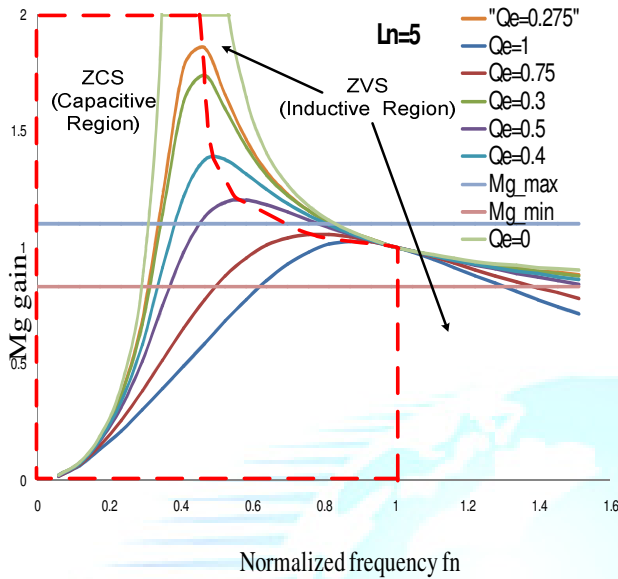

Fig.2. Gain characteristics of LLC

into two regions, ZVS region and ZCS region. The converter is characterized by two resonant frequencies. One resonant frequency corresponds to C_r, L_r , other one can be determined by L_m, C_r . As load increases the resonant frequency will shift to the higher resonant frequency. The two resonant frequencies can be given by

$$f_{r1} = \frac{1}{2\pi\sqrt{L_r C_r}} \quad (1)$$

$$f_{r2} = \frac{1}{2\pi\sqrt{(L_m + L_r) C_r}} \quad (2)$$

Above the resonant frequency f_{r1} the converter exhibits the same properties as that of SRC but below f_{r1} the properties of both SRC and PRC trying to dominate. At heavy load condition SRC will dominate but at light load condition the PRC will dominate. In order to have high efficiency the converter is designed so that it should operate near the f_{r1} .

Typical waveforms of LLC resonant converter is shown in the figure. Basically the operation of the LLC resonant converter depends upon the relationship between the frequency at which the switches are operated and the series resonant frequency (f_{r1}) of the converter. Operation of converter at different conditions results in different characteristics Converter can be basically operated in three different conditions ;

- Operation at resonant frequency (when $f_{r1} = f_{sw}$)

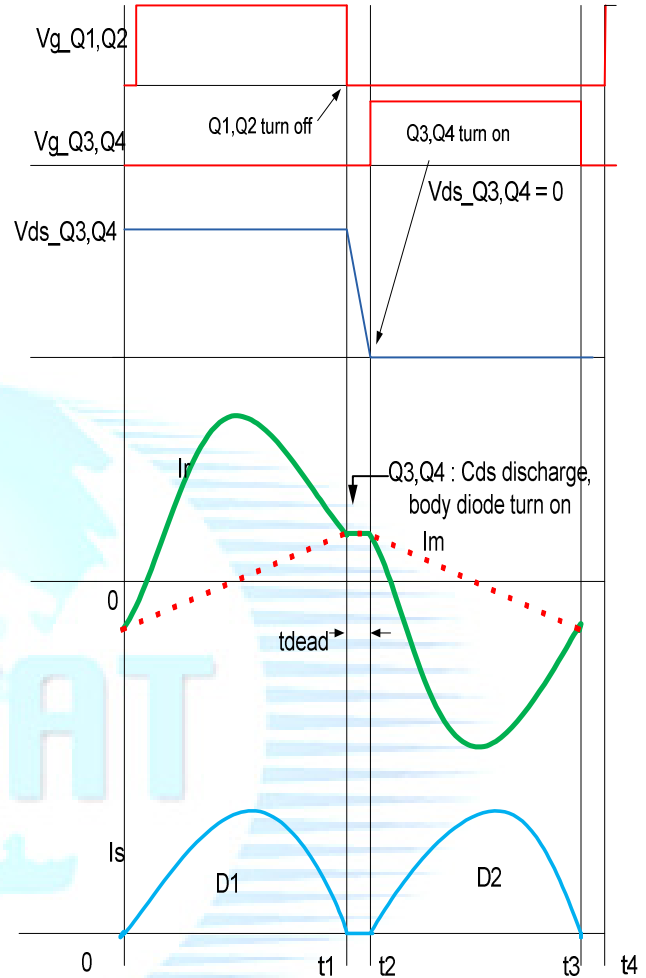

Fig.3. Typical waveforms of LLC

- Operation below resonant frequency (when $f_{r1} > f_{sw}$)
- Operation above resonant frequency (when $f_{r1} < f_{sw}$)

Operating the converter at resonant frequency f_{r1} is always preferred as it results in high efficiency and the resonant current can be approximated as sin-wave. Major drawback of operating the converter below f_{r1} is that the circulating current is very high since the secondary diodes are in discontinuous mode. This requires the resonant circuit to supply more circulating energy in order to supply the load with the same amount of energy. This additional circulating energy results in high conduction losses. But operating the converter above its series resonant frequency will result in very little circulating energy and hence very low losses. But the natural turn off of the secondary diodes is not possible and reverse recovery losses will be high. But the ZVS of primary operation is still possible but . operation above f_{r1} may cause significant increase in the switching frequency. The above analysis shows that

operating the converter at series resonant frequency is always preferred.

3. ZVS in LLC Resonant Converter

Major advantage of LLC is ZVS operation. ZVS is possible in that region of gain characteristics where the slope of the curve is negative. ZVS can be achieved by turning on the MOSFET at that point where it's drain to source voltage V_{DS} is zero. There are many ways to achieve this. One method of ensuring ZVS is to force MOSFET's body diode to conduct circulating current while the gating pulse is applied to it. As shown in Fig. at t_1 the switches Q1, Q2 are turned off and the gating pulse to Q3, Q4 is applied only after dead time t_{dead} . During this dead time the resonant current reverse and it is diverted from Q1, Q2 to Q3, Q4. Before forward biasing the body diode of the switches Q3, Q4, C_{ds} , the drain to source capacitance of Q3, Q4 is discharged. Once the body diodes of switches Q3, Q4 are forward biased at t_2 the resonant current will starts flowing through it making voltage V_{ds} across the switch zero. Now the switches are turned on with ZVS condition

So in order to have successful ZVS a non zero current should be flowing in the same direction as when Q1, Q2 were on. This is achieved with the help of external inductor. This analysis holds good for ZVS turn on of switches Q1, Q2 also.

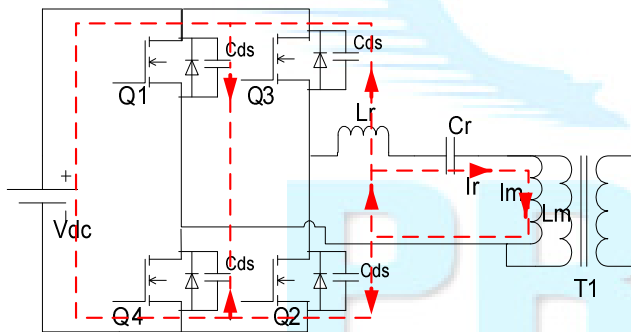

Fig.4. ZVS in LLC

In order to provide ZVS condition there should be an inductive impedance so that the resonant current will lag behind supply voltage. The magnetizing inductor L_m should be able to supply the required amount of inductive energy. To reduce the conduction losses the value of L_m should be high but to have a successful ZVS the value of L_m should be as small as possible. L_m is selected such that the magnetizing current should not be more than 20% of the resonant current. Therefore considering all conditions L_m is given by equation (3).

where

t_{dead} – dead time of the converter

C_{jc} – output capacitance of the switches

$$L_m = \frac{T t_{dead}}{16 C_{jc}} \quad (3)$$

4. PROTOTYPE DEVELOPMENT

Prototype of LLC resonant converter is developed with the design values given in the table. To design the converter we used first harmonic approximation method. In this method the resonant current is assumed to be sinusoidal. This is true at least at series resonant frequency f_r . According to this method the gain equation is developed which is given by

$$M_g = \left| \frac{L_n f_n^2}{[(L_n + 1) f_n^2 - 1] + j[(f_n^2 - 1) f_n Q_e L_n]} \right| \quad (4)$$

Where, f_n is the normalized frequency

L_n – inductance ratio

Q_e – quality factor

$$f_n = \frac{f_{sw}}{f_r}$$

$$L_n = \frac{L_m}{L_r}$$

$$Q_e = \frac{\sqrt{L_r / C_r}}{R_{ac}}$$

The gain function described by the equation (4) depends on three variables L_n , f_n , and Q_e . For a particular design the value of L_n and Q_e are fixed. Gain can be varied only by varying the switching frequency i.e. f_n . Hence we can consider L_n , Q_e as dummy variables and the only control variable is f_n . Family of curves are plotted as shown in the fig.2. As we can see from the gain curve we observe that as the value of the quality factor Q_e increases with L_n fixed the curve becomes narrower results in narrow frequency control band. This is expected since C_r and L_n are fixed and Q_e depends only on load. As a matter of interest we shall consider two important conditions :

- If the load is open circuited then the value of $Q_e = 0$ and the switching frequency $f_{sw} = f_{r2}$. Theoretically the corresponding peak value of gain function is ∞ .
- If the load is short-circuited then the value of Q_e is ∞ and the switching frequency $f_{sw} = f_{r1}$.

Theoretically the corresponding peak value of gain function is zero.

Parameters	Initial Design	Final Design
Input V_{in_nom}	72V	72V
Output V_{out}	400V	400V
P_o	2.4Kw	2.4Kw
L_m	8.15 μ H	8.5 μ H
L_r	1.31 μ H	1.51 μ H
C_r	2.51 μ F	2.62 μ F
Q_e	0.42	0.42
L_n	6	6
f_r	86000Hz	82400Hz

Fig.1. Design Parameters

The design data of the prototype developed is given in the table. The prototype developed is shown in the fig. Battery is used of 72V is used as input. Here in this we initially tried to develop integrated magnetic structure by combining resonant inductor. But due to the difficulties in adjusting the value of resonant inductor we couldn't develop integrated structure. Instead the resonant inductor is connected in series the transformer primary. Voltage mode control is used here. The switching frequency of the resonant converter is varied according to the variation in the output hence the output is regulated. Gate driver IC used here is FAN7390, which is a monolithic high-and low-side gate drive IC. It can drive high speed MOSFETs and IGBTs that operate up to +600V. IPP041N12N3 G MOSFET is used as a switch.



Fig.5.Prototype

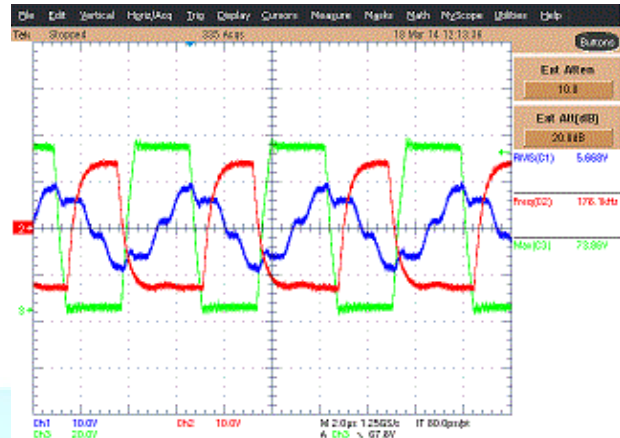

Fig.6. at 72 V and No-load

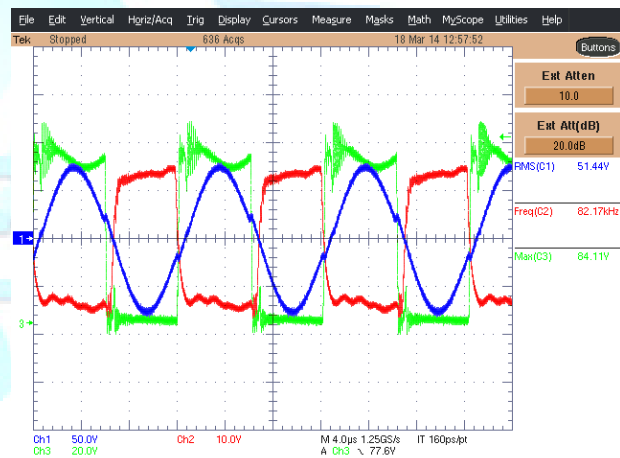

Fig.7. t 72 V and full load

Developed prototype is tested for various load conditions. Fig 6 shows the no-load test waveforms. Under no-load the resonant current is highly distorted and the switching frequency is very high. In the fig 7 full load test waveform is shown. The resonant current is almost sinusoidal and the switching frequency is almost equal to series resonant frequency.

4. Conclusions

In this paper full bridge LLC resonant converter is discussed and its design procedure also presented. In this project work we successfully designed full bridge LLC resonant converter with the specification $P_o=2.4KW, V_o=400V, V_{in}=72V$ efficiency =95%. Prototype of designed LLC resonant converter is realized. But due to the difficulties in adjusting the value of resonant inductor we did not use the principle of integrated magnetics. So in order to enjoy all the advantages of LLC resonant converter it is recommended to realize the integrated magnetic structure of the transformer. Various tests are

conducted. From the test results various characteristics of LLC resonant converter were studied.

References

- [1] “LLC Resonant Converter for Front End DC/DC Conversion”, Bo Yang and Fred C. Lee Applied Power Electronics Conference and Exposition, 2002. APEC 2002. Seventeenth Annual IEEE (Volume:2), 2002, Dallas, TX
- [2] “Design Considerations for an LLC Resonant Converter” Hangseok Choi, Fairchild Semiconductor,82-3, Dodang-dong, Wonmi-gu, Bucheon-si, Gyeonggi-do, Korea, Fairchild Power Seminar 2007
- [3] “A Comparison Of Half-Bridge Resonant Converter Topologies”, RobertL Steigerwald IEEE Transactions On Power Electronics, Vol. 3, No. 2, April 1988.
- [4] Integrated Magnetic for LLC Resonant Converter Bo Yang, Rengang Chen and Fred C. Lee, Applied Power Electronics Conference and Exposition, 2002. APEC 2002. Seventeenth Annual IEEE (Volume:1), Dallas, TX, 346 - 351 vol.1
- [5] “Effect Of A Split Transformer Leakage Inductance In The Llc Converter With Integrated Magnetics” Spiazzi, s. Buso, .Power Electronics Conference (COBEP), IEEE, 2013 brazilian, 27-31 oct. 2013, 135 - 140
- [6] “Optimal Design Methodology for LLC Resonant Converter”, Bing Lu, Wenduo Liu, Yan Liang, Fred C. Lee, Jacobus D. van Wyk, Applied Power Electronics Conference and Exposition, 2006. APEC '06. Twenty-First Annual IEEE , 19-23 March 2006
- [7] Power electronics, converters, application, design” III edition Mohan, Undeland, Robbins.
- [8] “FHA-Based Voltage Gain Function with Harmonic Compensation for LLC Resonant Converter” Applied Power Electronics Conference and Exposition (APEC), 2010 Twenty-Fifth Annual IEEE, 21-25 Feb. 2010, Palm Springs, CA, 1770 - 1777
- [9] “Loss Analysis of Half-Bridge LLC Resonant Converter”, Chun-Hsu Yang, Tsomg-Juu Liang, Kai-Hui Chen, Ji-Shiuan Li, Ji-Shiang , Future Energy Electronics Conference (IFEEC), 2013, Tainan, 3-6 Nov. 2013
- [10] “Analysis and Design of LLC Resonant Converter Considering Rectifier Voltage Oscillation”, Ki-Bum Park¹, Bong-Chul Kim¹, Byoung-Hee Lee¹, Chong-Eun Kim², Gun-Woo Moon¹, and Myung-JoongYounl, Energy Conversion Congress and Exposition, 2009. ECCE 2009, 20-24 Sept. 2009, San Jose, CA
- [11] “Optimal Design Method for LLC Resonant Converter with Wide Range Output Voltage” Zhijian Fang, Shanxu Duan, Changsong Chen and Xi Chen, Applied Power Electronics Conference and Exposition (APEC), 2013 Twenty-Eighth Annual IEEE, 17-21 March 2013, Long Beach, CA, 2106 – 2111
- [12] P.Reddi Kiran, Dr. Srivani S.G titled “Efficient Current Limiting Technique for Voltage Mode Controlled DC-DC Converters ” International Journal of Scientific & Engineering Research, Volume 4, Issue 10, October-2013 ISSN 2229-5518.Texas, USA.